

## **X105R FUEL WATER SEPARATOR / CATCHCAN FITMENT INSTRUCTIONS**

TOYOTA LAND CRUISER 200 Series - See RYCO catalogue for specific application details.

The Ryco X105R kit includes mounting bracket specifically designed for the vehicle, and all components required to complete the installation of Ryco Z980SK16 series fuel water separator and RCC351 series catchcan. It is recommended that the installation is conducted by a qualified mechanic following the procedures in this instruction sheet.



**SECTION 1**  
**METAL BRACKET**

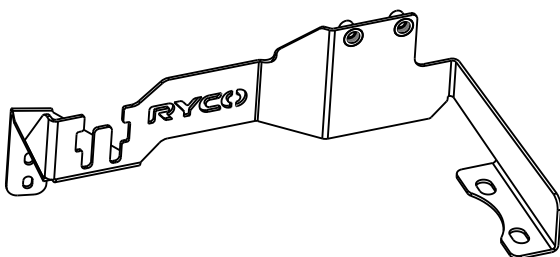

**SECTION 2**  
**FUEL WATER SEPARATOR**



**SECTION 3**  
**CATCHCAN**

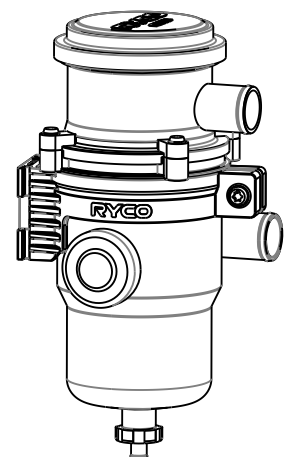

**COMPONENTS INCLUDED IN X105R KIT**

**X105R PARTS LIST - BRACKET / FUEL FILTER COMPONENTS BOX**

MS4044  
CABLE TIE x 10



MS4096A  
QUICK CONNECTOR x 2

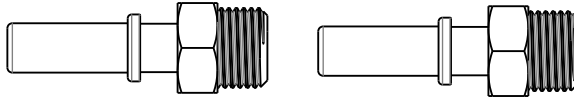

MS4121  
ELBOW CONNECTOR x 2

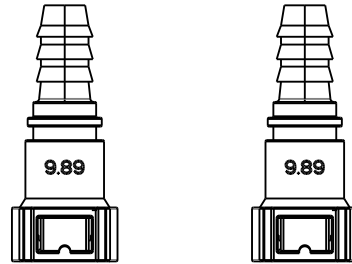

MS4041A  
FUEL HOSE CLAMP x 2

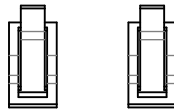

**X105R PARTS LIST - CRANKCASE VENT. FILTER COMPONENTS BOX**

MS4089  
PVC HOSE x 1M

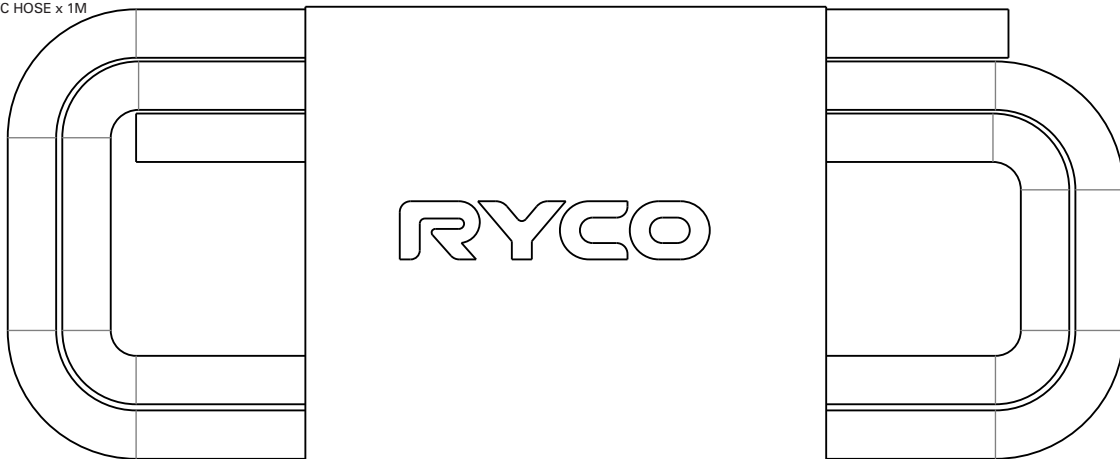

MS4091  
PCV HOSE CLAMP x 2

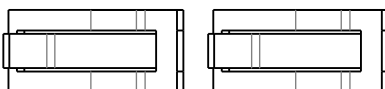

MS4092  
PCV HOSE CLAMP x 2



MS4090  
DRAIN VALVE x 1

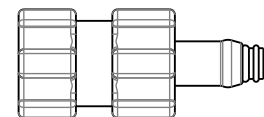

MS4093  
DRAIN HOSE CLAMP x 2



**COMPONENTS INCLUDED IN X105R KIT**

**PARTS LIST - BRACKET, FUEL FILTER & CATCHCAN COMPONENTS**

FB9802C  
MOUNTING BRACKET x 1

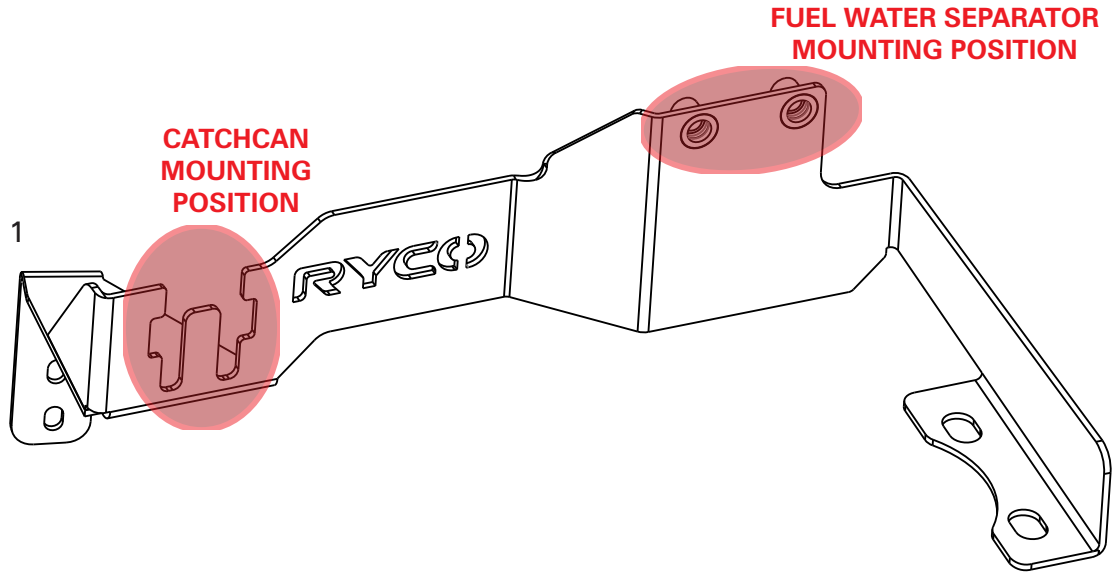

MF9802  
FUEL HOSE x 1

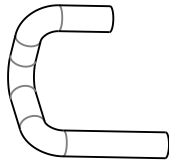

MH9802A PCV HOSE x 1

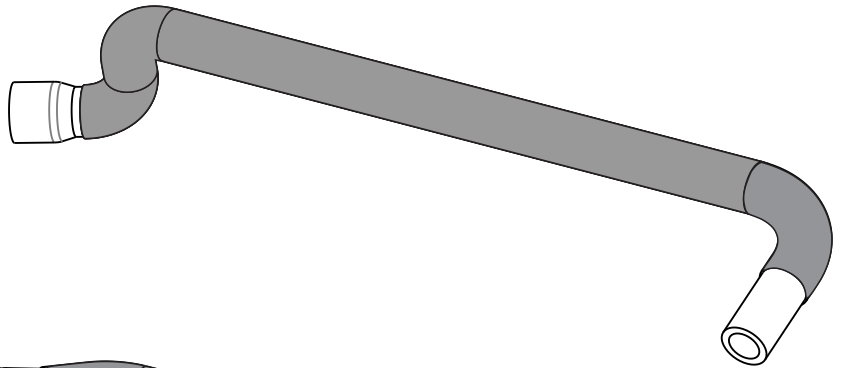

MH9802B PCV HOSE x 1

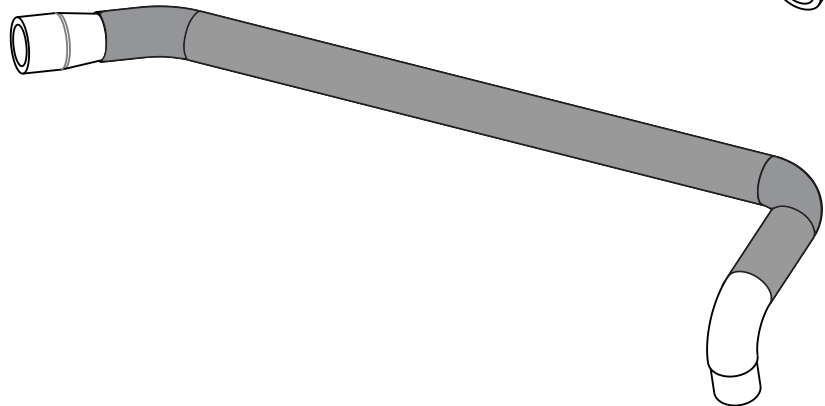

# X105R FUEL WATER SEPARATOR / CATCHCAN FITMENT INSTRUCTIONS

## SECTION 1 METAL BRACKET FITMENT

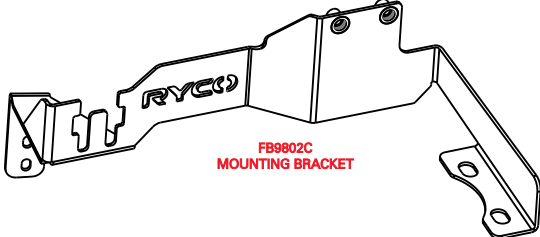
PARTS REQUIRED	TOOLS & PPE'S REQUIRED
 <p style="text-align: center;">FB9802C MOUNTING BRACKET</p>	<ul style="list-style-type: none"> <li>* WORK GLOVES</li> <li>* RACHET SET</li> </ul>

### WORK PROCEDURE

1. Locate the wiring harness on the passenger side firewall, next to rear fuse box. Remove from the harness bracket by lifting up the locking tab using a screwdriver, then pull out the wiring harness from the bracket. (see Fig. 1). Remove the wiring harness bracket by undoing the two nuts. Store bracket for safe keeping.
2. Locate the factory fuel filter on the passenger side of the engine bay. Remove the two nuts (marked B in Fig. 2) securing the factory filter to the vehicle. Lift the factory filter housing and fit Ryco filter metal bracket in the same position as the factory fuel filter. Aligning the other end of the Ryco bracket holes to the wiring harness bracket studs. Place the factory filter housing on top of the Ryco filter bracket and loosely refit factory nuts previously removed. Secure the bracket onto the firewall by loosely installing two factory nuts (marked A in Fig. 2).

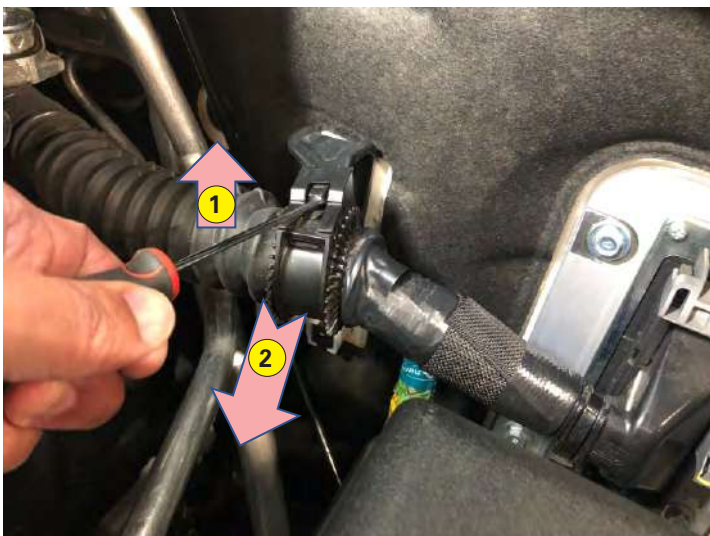

FIG. 1 WIRE HARNESS BRACKET IN ENGINE BAY

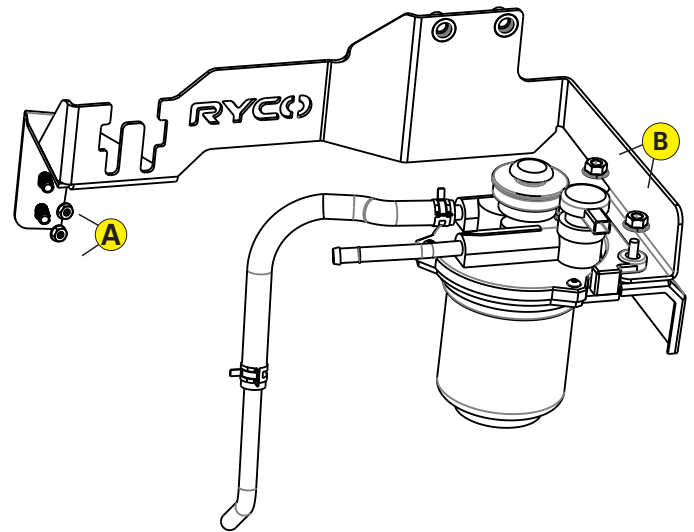

FIG. 2 BRACKET INSTALLATION

3. Tighten all fasteners

4. Secure the wiring harness to the Ryco metal bracket using a cable tie as shown in Fig. 3.

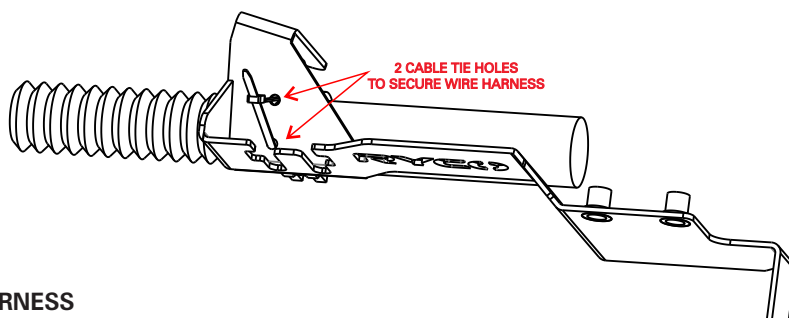
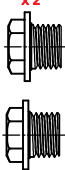
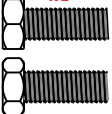

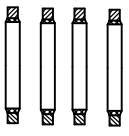

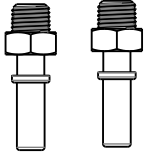

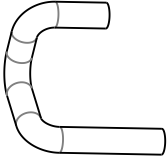



FIG. 3 SECURE WIRE HARNESS

# X105R FUEL WATER SEPARATOR / CATCHCAN FITMENT INSTRUCTIONS

## SECTION 2 FUEL WATER SEPARATOR INSTALLATION

PARTS REQUIRED			TOOLS & PPE'S REQUIRED		
<p>M18 PLUG x 2</p>  <p>M10 BOLT x 2</p>  <p>M10 FLANGE NUT x 2</p>  <p>RUBBER BONDED WASHER x 4</p>  <p>M10 WASHER x 2</p> 	 <p>Z980SK16 FUEL WATER SEPARATOR</p>	<p>MS4096A QUICK CONNECTOR x 2</p>  <p>MS4041A FUEL HOSE CLAMP x 2</p> 	<p>MF9802 MOLDED FUEL HOSE x 1</p> 	<p>MS4081 STRAIGHT CONNECTOR x 2</p> 	<ul style="list-style-type: none"> <li>* WORK GLOVES</li> <li>* RACHET SET</li> <li>* HOSE CLAMP PLIERS</li> <li>* RAGS</li> </ul>

### WORK PROCEDURE

1. Select the supplied quick connectors that fit the Ryco fuel water separator head.
2. Locate the blanking plugs supplied with the fuel water separator.
3. Install the Ryco fuel water separator head with metal quick connectors, blanking plugs and rubber bonded washers, as per Fig 4. Tighten blanking plugs(on Port 3 & 4) and quick connectors (on Port 1 & 2).
4. Install the MS4081 straight connectors by pushing them onto the metal quick connector until you hear a "click" at the filter head assembly as shown in Fig. 5.

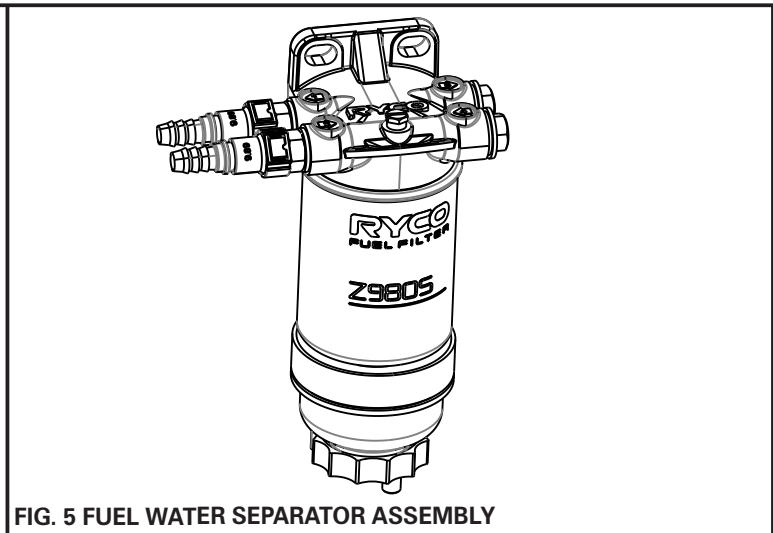
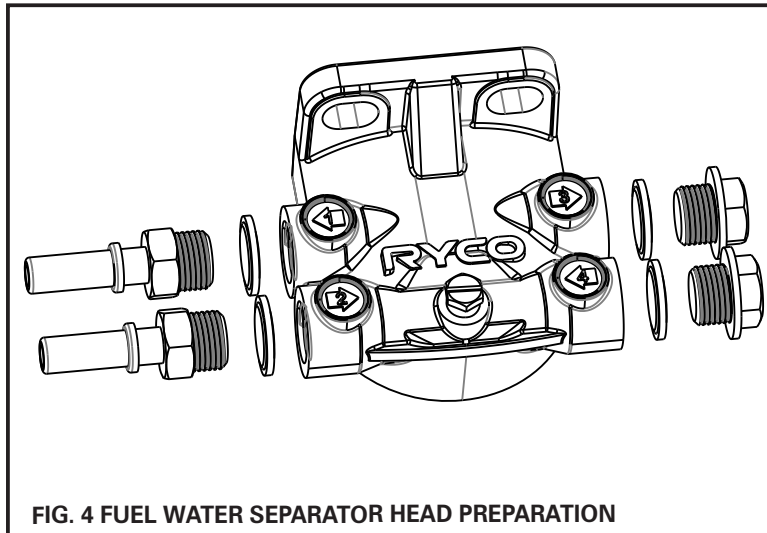

# X105R FUEL WATER SEPARATOR / CATCHCAN FITMENT INSTRUCTIONS

## SECTION 2 FUEL WATER SEPARATOR INSTALLATION (CONTINUED)

### WORK PROCEDURE (CONTINUED)

5. Mount the Z980SK16 fuel filter assembly onto the metal bracket using the two (2) black M10 bolts and washers supplied with the Z980SK16.
6. Locate the factory fuel inlet hose at the factory fuel filter. Loosen the factory fuel hose clamp and disconnect the fuel supply line from the factory filter. Have a rag ready to capture any diesel that may spill out of the fuel line and the fuel filter inlet pipe. Connect the factory fuel inlet hose to the Z980SK16 inlet fitting, and secure with a fuel hose clamp. See Fig 6 for inlet hose routing.
7. Connect the supplied MF9802 fuel hose to the outlet port fitting of the Z980SK16 and connect the other end to the factory fuel filter inlet port and secure with a hose clamp. See Fig 7 for fuel hose routing.
8. Ensure all hose clamps are secure.
9. Locate the priming button on top of the factory fuel filter. Prime the fuel system by pumping the button repeatedly until you feel it go hard and become difficult to press any further. The priming process could take approximately 5 - 10 minutes.

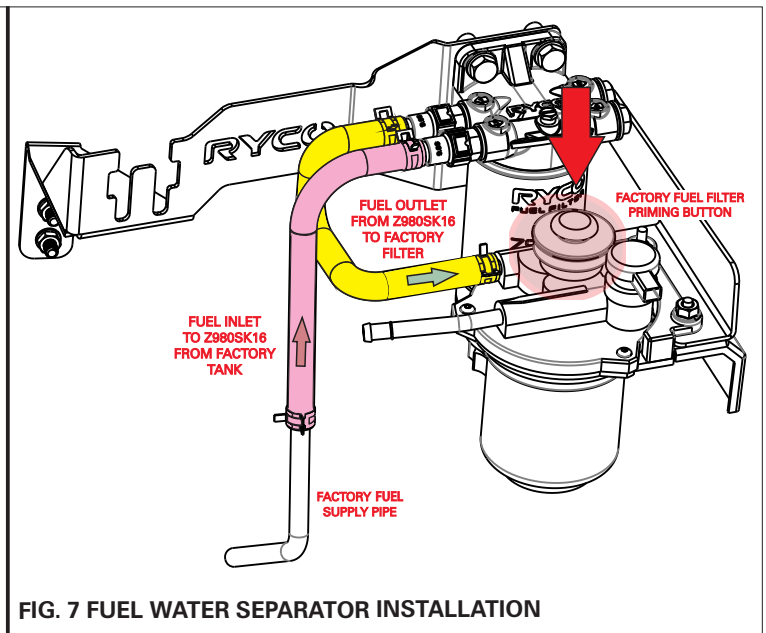
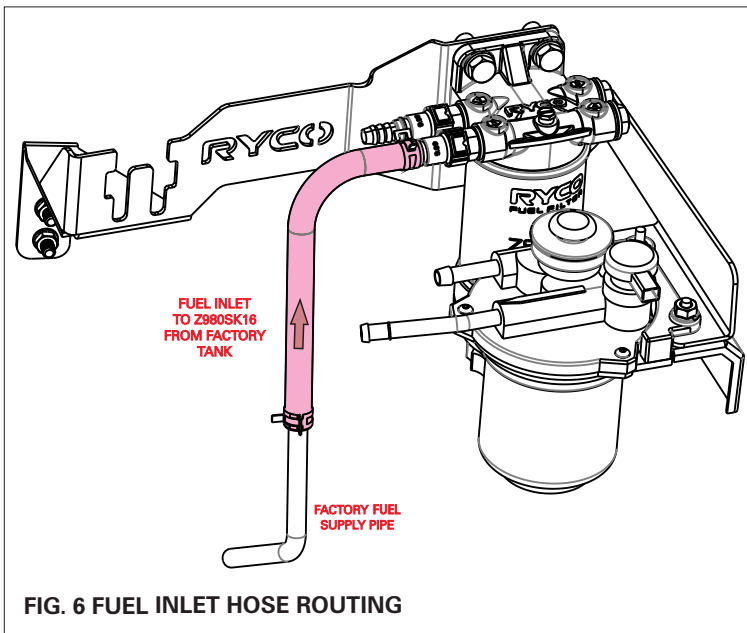



10. Start the engine and check the Z980SK16 fuel filter, fittings and hoses for any leaks.

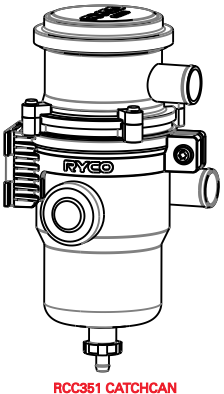
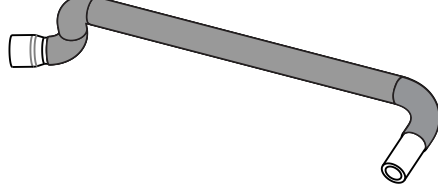
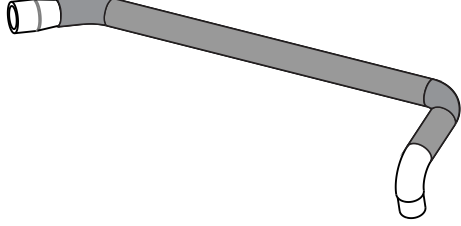

# X105R FUEL WATER SEPARATOR / CATCHCAN FITMENT INSTRUCTIONS

## SECTION 3 CATCHCAN INSTALLATION

PARTS REQUIRED		TOOLS & PPE'S REQUIRED
 <p>RCC351 CATCHCAN</p>	<p>MH9802A PCV HOSE x 1</p>  <p>MH9802B PCV HOSE x 1</p> 	<p>MS4091 PCV HOSE CLAMP x 2</p>  <p>MS4092 PCV HOSE CLAMP x 2</p> 
		<ul style="list-style-type: none"> <li>* WORK GLOVES</li> <li>* RACHET SET</li> <li>* HOSE CLAMP PLIERS</li> </ul>

## WORK PROCEDURE

1. Mount the catchcan onto the X105R bracket by sliding the RCC351 nylon bracket onto the catchcan mounting position. Rotate the RCC351 so the ports are facing toward the front of the vehicle, as per Fig.8 below.
2. Locate the factory PCV valve at the front of the engine, as per Fig. 9. Remove the factory PCV hose .

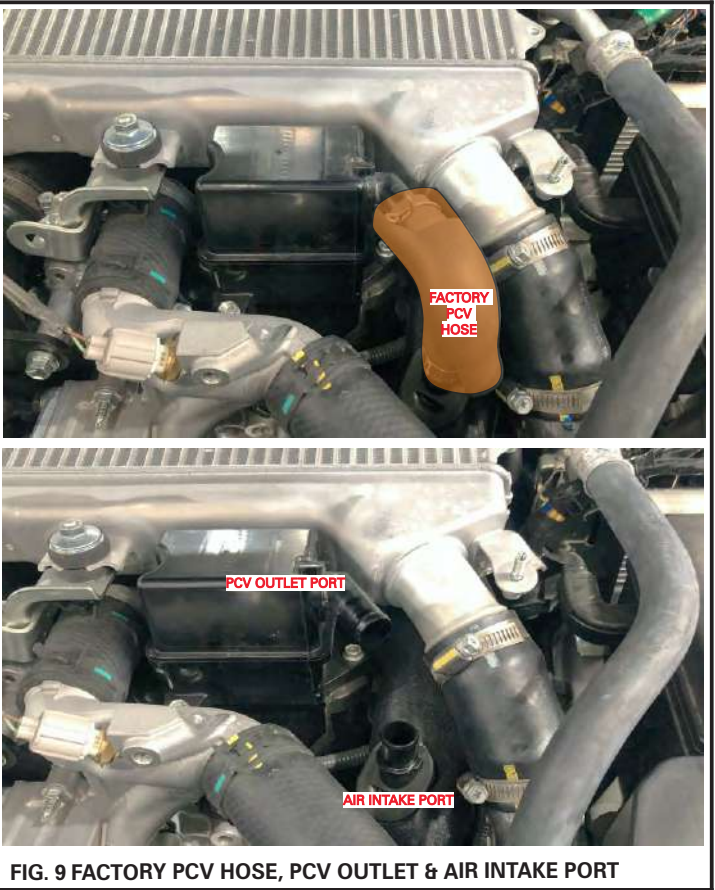
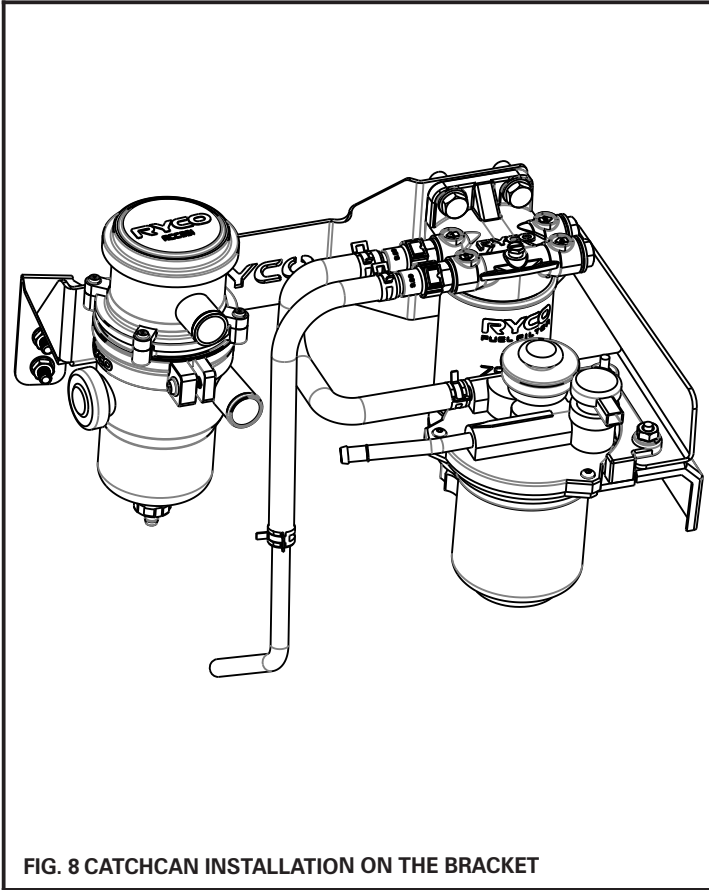

## X105R FUEL WATER SEPARATOR / CATCHCAN FITMENT INSTRUCTIONS

### SECTION 3 CATCHCAN INSTALLATION (CONTINUED)

#### WORK PROCEDURE (CONTINUED)

3. Connect the larger diameter end of the MH9802A PCV hose (shown blue in Fig. 10.) to the RCC351 lower inlet port, and connect the smaller diameter end of the PCV hose to the engine PCV outlet port and secure with a supplied hose clamp.
4. Route MH9802B (shown green in Fig. 10.) along side MH9802A and connect the large diameter end to the upper port of the RCC351 and secure with a supplied hose clamp.
5. Check both PCV hoses are not jammed or kinked by the surrounding engine parts.

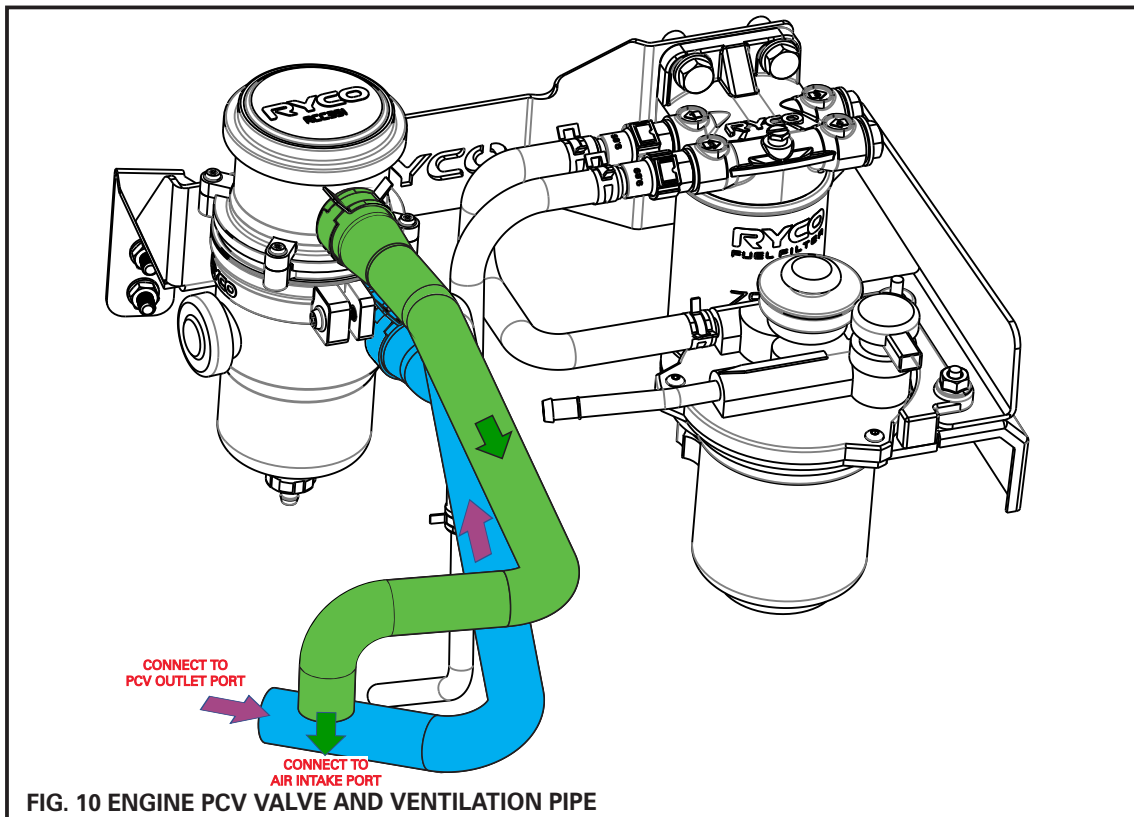

#### DRAIN HOSE INSTALLATION PROCEDURE (OPTIONAL)

1. To install the drain hose, remove the drain plug from the bottom of RCC351, take out the rubber seal from the plug and refit. Insert the drain hose and secure it with the supplied spring clamp. Insert the hose drain tap to the other end and use the zip ties to secure the hose. To drain, pull back the red section until all oil has drained out.
2. If it has been fitted without using the drain hose supplied, simply slide the RCC351 off the RVSK bracket and remove the drain plug on the unit and let the oil drain onto a pan or bottle.

