

X106R FUEL WATER SEPARATOR / CATCHCAN FITMENT INSTRUCTIONS

TOYOTA LAND CRUISER 70 Series - See RYCO catalogue for specific application details.

The Ryco X106R kit includes mounting bracket specifically designed for the vehicle, and all components required to complete the installation of Ryco Z980K16 series fuel water separator and RCC351 series catchcan. It is recommended that the installation is conducted by a qualified mechanic following the procedures in this instruction sheet.

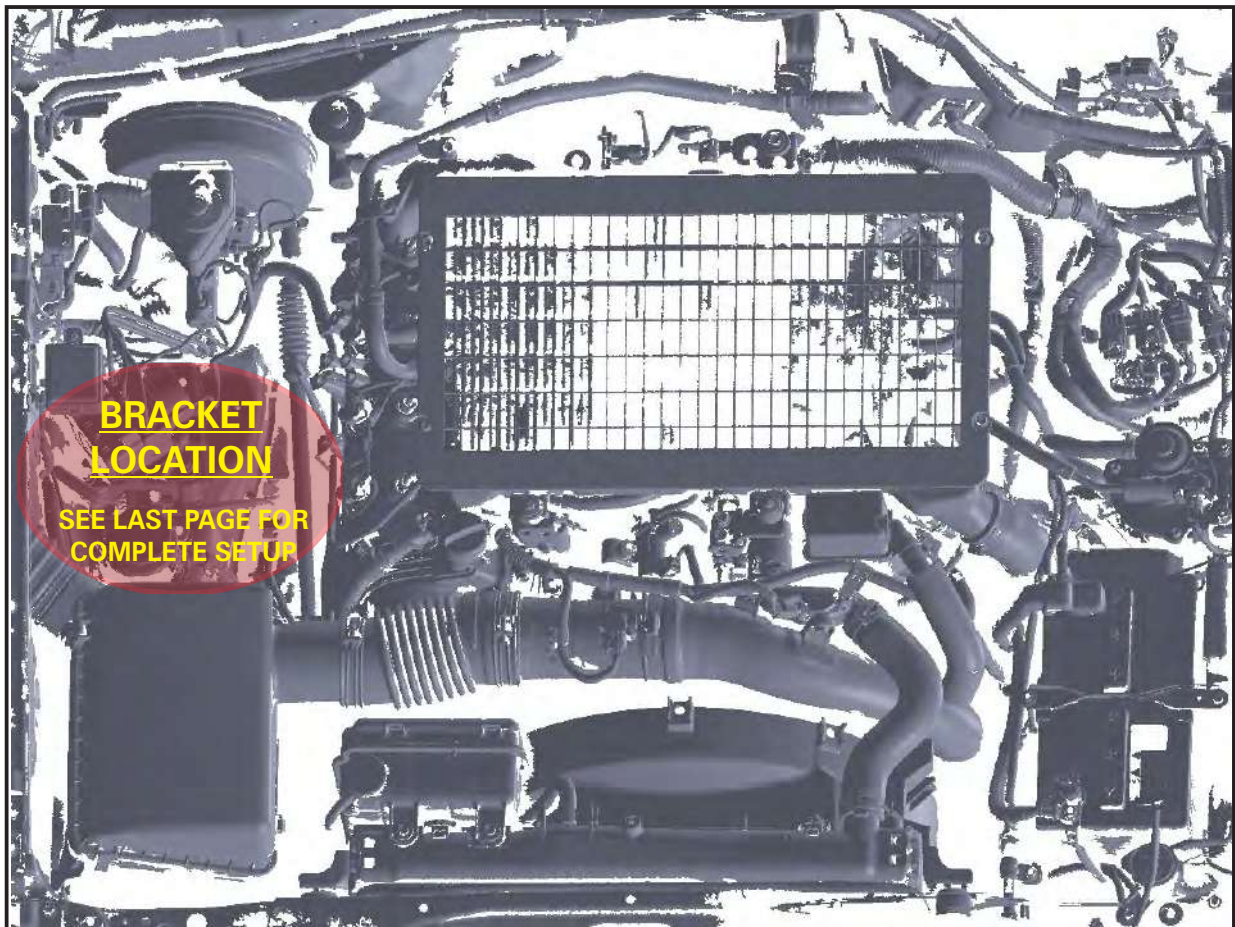

SECTION 1
METAL BRACKET

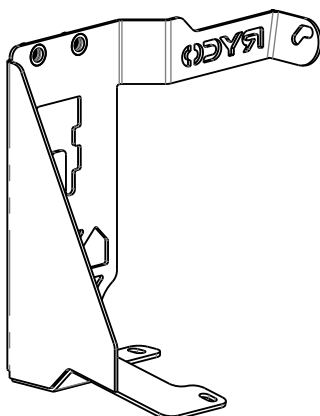

SECTION 2
FUEL WATER SEPARATOR

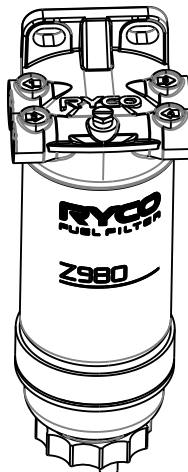

SECTION 3
CATCHCAN

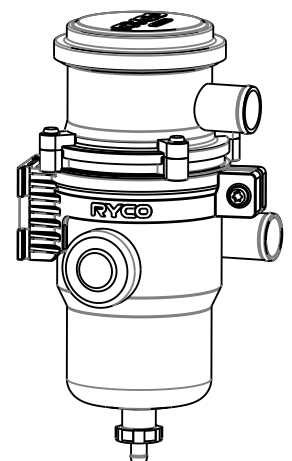

COMPONENTS INCLUDED IN X106R KIT

X106R PARTS LIST - BRACKET / FUEL FILTER COMPONENTS BOX

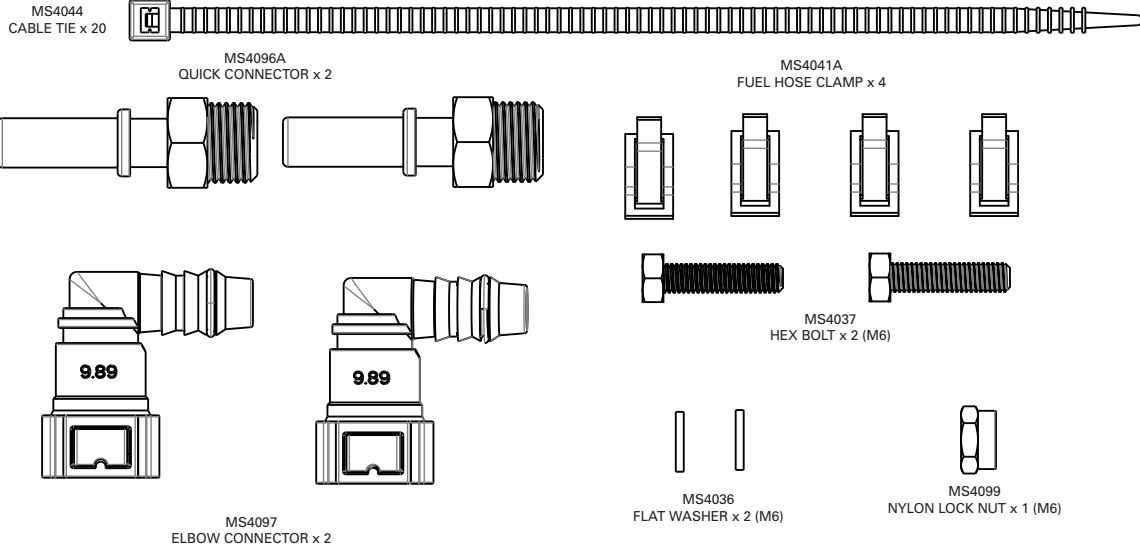

X106R PARTS LIST - CRANKCASE VENT. FILTER COMPONENTS BOX

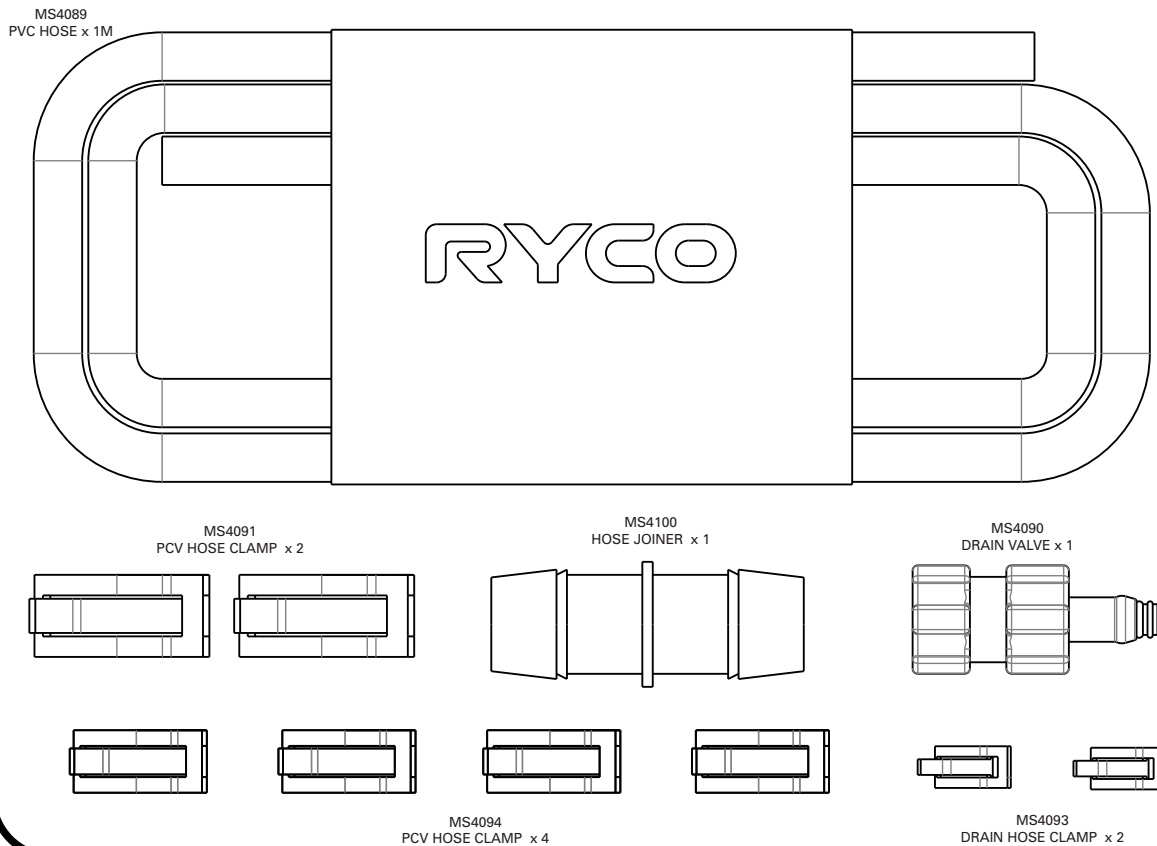

COMPONENTS INCLUDED IN X106R KIT

PARTS LIST - BRACKET, FUEL FILTER & CATCHCAN COMPONENTS

FB9811C
MOUNTING BRACKET x 1

FUEL WATER SEPARATOR
MOUNTING POSITION

CATCHCAN
MOUNTING POSITION

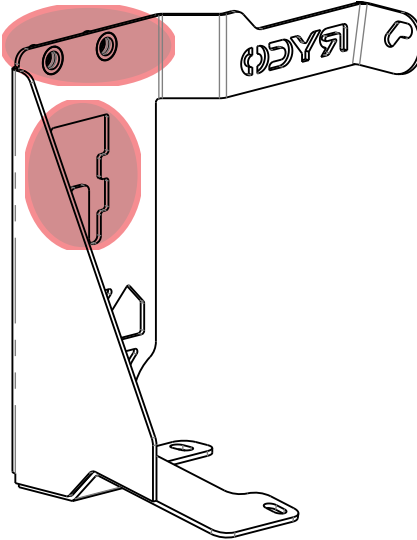

HF9811
FUEL HOSE x 2
(2000mm)

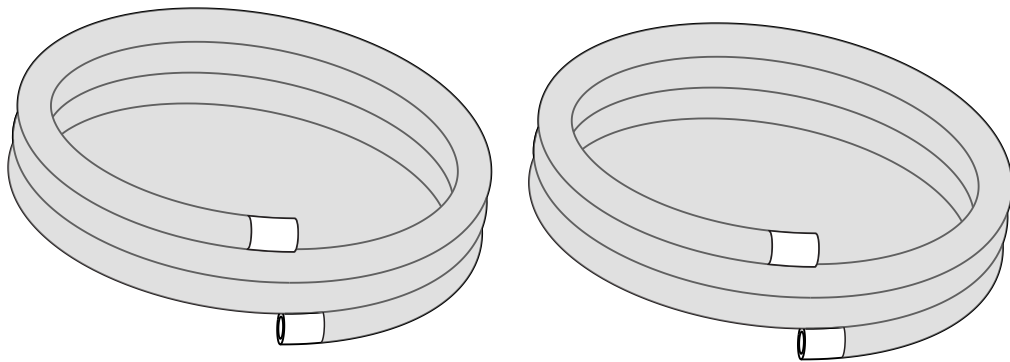

MH9811A PCV HOSE x 1

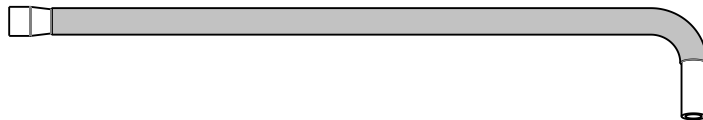

MH9811B PCV HOSE x 1



X106R FUEL WATER SEPARATOR / CATCHCAN FITMENT INSTRUCTIONS

SECTION 1 METAL BRACKET FITMENT

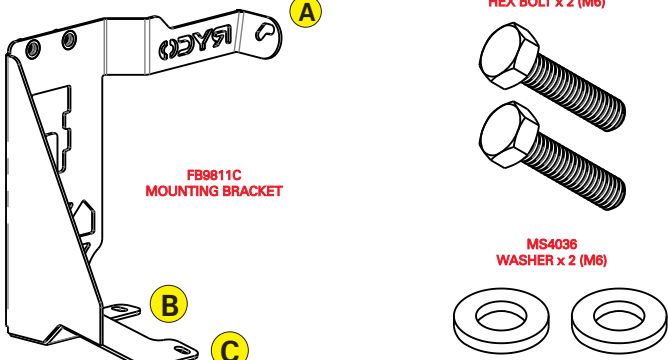
PARTS REQUIRED	TOOLS & PPE'S REQUIRED
 <p>MS4037 HEX BOLT x 2 (M6)</p> <p>MS4036 WASHER x 2 (M6)</p> <p>FB9811C MOUNTING BRACKET</p>	<p>* WORK GLOVES * RACHET SET</p>

WORK PROCEDURE

1. Locate the power steering reservoir behind the airbox. Remove the factory M6 bolt holding the power steering reservoir mount closest to the engine, see Fig. 2. (Note: You do not need to remove the other factory bolt)
2. Position the bracket in the engine bay as per Fig. 1, aligning the hole at Point **B** on the bracket under the power steering reservoir mount at point **B** and loosely refit the factory bolt.
3. Note the position of the threaded hole at Point **C** in the engine bay, and the threaded hole at Point **A** on the side of the engine bay. Secure the bracket onto the vehicle by loosely installing a supplied M6 bolt and washer at both points.

TIP: To assist with clearance to fit the catchcan behind the airbox, position the bracket as far back as the bracket mounting holes allow. For added security, you may wish to secure the M6 bolt at Point **C** with the supplied M6 nylon lock nut by accessing the end of the bolt from the drivers side front wheel house.

4. Tighten all fasteners as per Fig. 2.

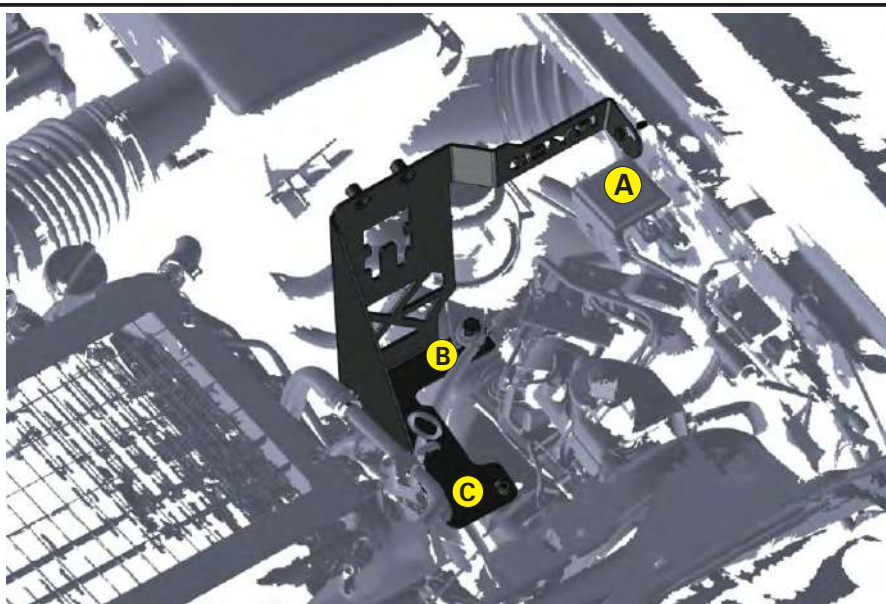

FIG. 1 BRACKET IN ENGINE BAY

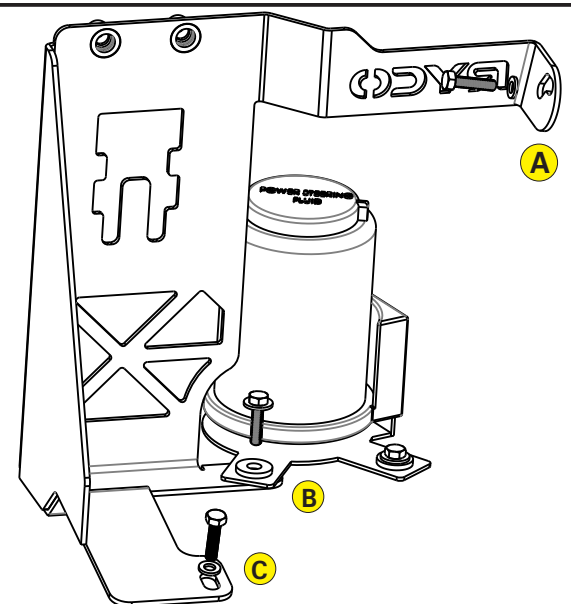

FIG. 2 BRACKET INSTALLATION

X106R FUEL WATER SEPARATOR / CATCHCAN FITMENT INSTRUCTIONS

SECTION 2 FUEL WATER SEPARATOR INSTALLATION

PARTS REQUIRED		TOOLS & PPE'S REQUIRED	
<p>M16 PLUG x 2</p> <p>M10 BOLT x 2</p> <p>RUBBER BONDED WASHER x 4</p> <p>M10 FLANGE NUT x 2</p> <p>M10 WASHER x 2</p> <p>RYCO Z980K16 FUEL WATER SEPARATOR</p>	<p>MS4096A QUICK CONNECTOR x 2</p> <p>HF9811 FUEL HOSE x 2 (2000mm)</p> <p>MS4041A FUEL HOSE CLAMP x 4</p> <p>MS4097 ELBOW CONNECTOR x 2</p>	<p>* WORK GLOVES</p> <p>* RACHET SET</p> <p>* HOSE CLAMP PLIERS</p> <p>* RAGS</p>	

WORK PROCEDURE

1. Install the Ryco fuel water separator head with metal quick connectors, blanking plugs and rubber bonded washers, as per Fig 3. Tighten blanking plugs(on Port 1 & 2) and quick connectors (on Port 3 & 4).
2. Install two (2) of the supplied elbow connectors onto one end of both supplied fuel hoses and install four (4) supplied fuel hose clamps onto both ends of both fuel hoses, as per Fig. 4. Do not tighten fuel hose clamps yet.

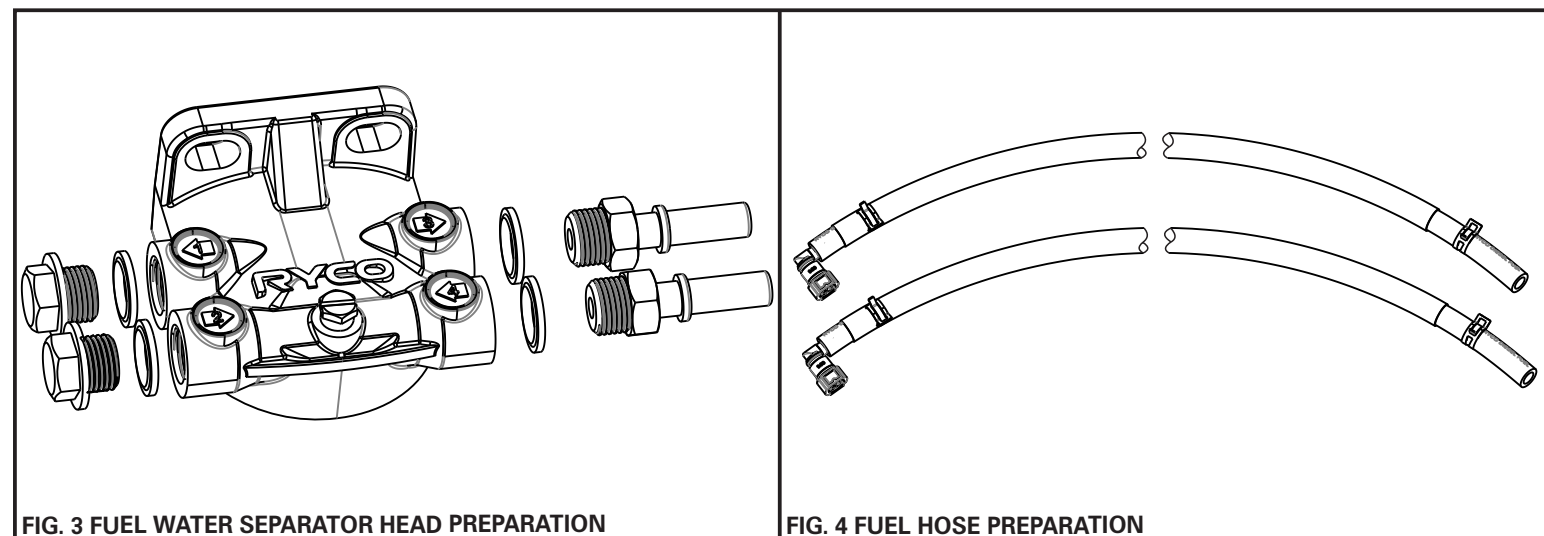

FIG. 3 FUEL WATER SEPARATOR HEAD PREPARATION

FIG. 4 FUEL HOSE PREPARATION

X106R FUEL WATER SEPARATOR / CATCHCAN FITMENT INSTRUCTIONS

SECTION 2 FUEL WATER SEPARATOR INSTALLATION (CONTINUED)

WORK PROCEDURE (CONTINUED)

5. Locate the factory fuel filter on the passenger side of the engine bay. Locate the factory fuel inlet hose at the factory fuel filter. Loosen the factory fuel hose clamp and disconnect the fuel supply line from the factory filter, as per Fig. 5. Have a rag ready to capture any diesel that may spill out of the fuel line and the fuel filter.
6. Trace the other end of the fuel supply line and disconnect it from the metal factory fuel supply pipe, as per Fig. 5. Remove the factory fuel supply line from the vehicle and store for safe keeping. Have a rag ready to capture any diesel that may spill out of the fuel lines.
7. Mount the Z980K16 fuel filter assembly onto the metal bracket facing the rear of the engine bay using the two (2) black M10 bolts and washers supplied with the Z980K16.
8. Connect one of the supplied fuel hoses to the inlet port of the Z980K16 (coloured brown in Fig. 6) by pushing the elbow connector onto the metal quick connector until you hear a "click", and route the other end over the ABS pipes toward the rear of the engine bay up to the back corner. From the corner, run the hose behind the brake booster and along firewall to the passenger side of the vehicle, running under the heater hose bracket. Complete the routing by running the hose to the factory fuel supply pipe and connecting with a hose clamp. See Fig. 7 for hose routing.
9. Connect the second hose to the outlet port of the Z980K16 (coloured green in Fig. 6) by pushing the elbow connector onto the metal quick connector until you hear a "click", and route the other end under the ABS pipes and up to the back corner of the engine bay. Route the remaining fuel hose similar to the other fuel hose as per Fig. 7. Connect the end of the fuel hose to the factory fuel filter inlet port and secure with a hose clamp.
10. Ensure all hose clamps are secure. For added security, use the supplied cable ties to secure the fuel hoses at regular intervals to the factory cable along the firewall and heater hose bracket.
11. Locate the priming button on top of the factory fuel filter. Prime the fuel system by pumping the button repeatedly until you feel it go hard and become difficult to press any further. The priming process could take approximately 5 - 10 minutes.

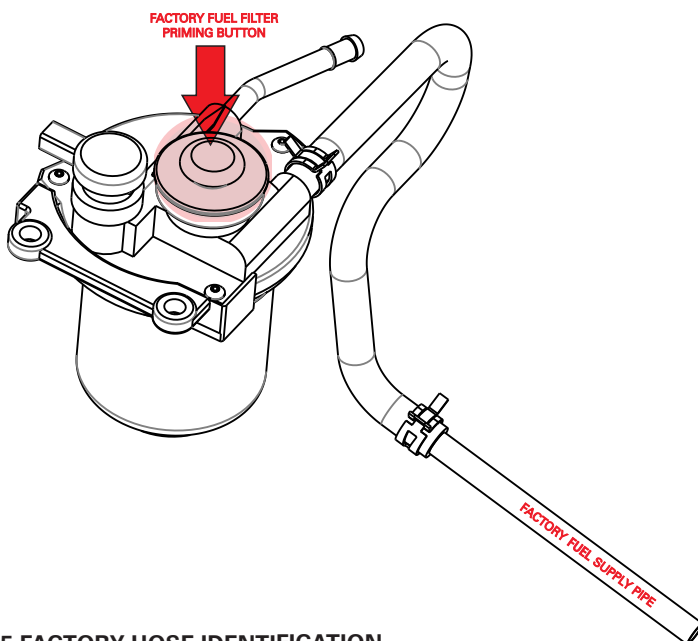

FIG. 5 FACTORY HOSE IDENTIFICATION

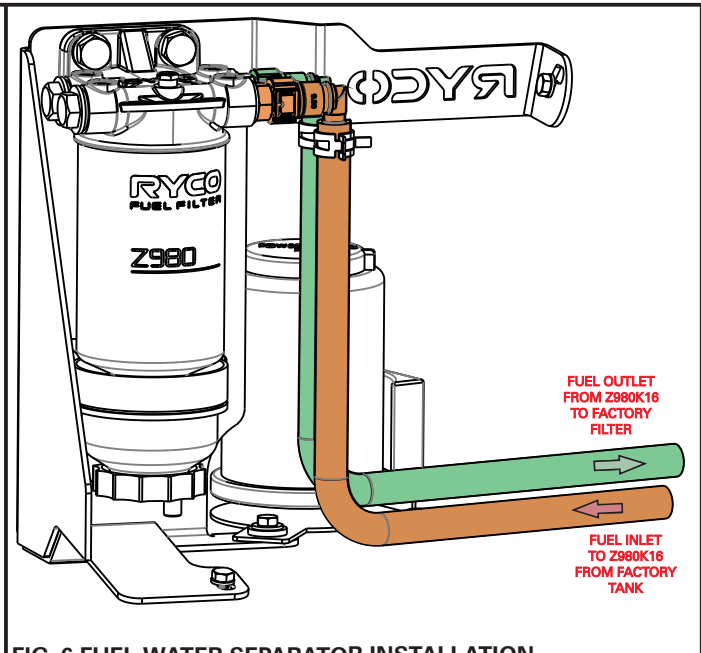
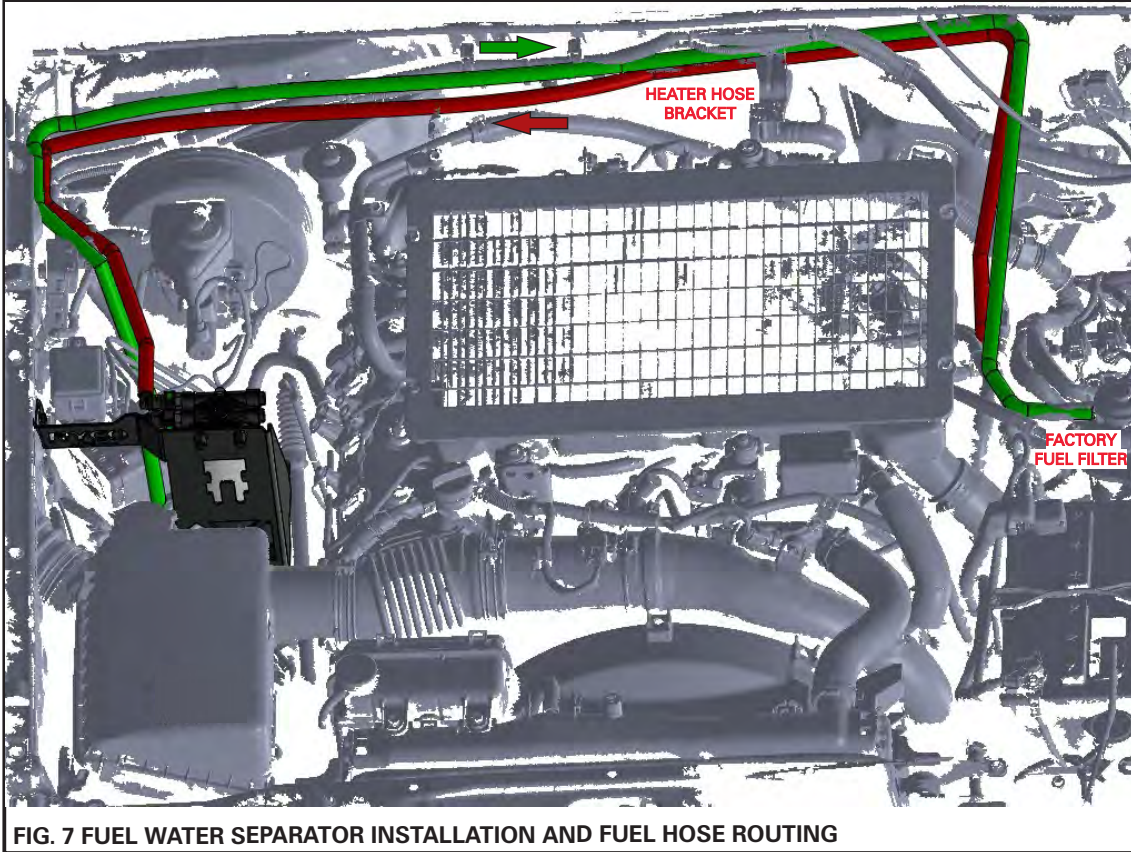

FIG. 6 FUEL WATER SEPARATOR INSTALLATION







X106R FUEL WATER SEPARATOR / CATCHCAN FITMENT INSTRUCTIONS

SECTION 2 FUEL WATER SEPARATOR INSTALLATION (CONTINUED)

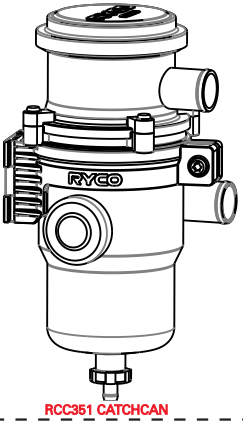

X106R FUEL WATER SEPARATOR / CATCHCAN FITMENT INSTRUCTIONS

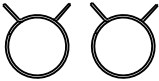
SECTION 3 CATCHCAN INSTALLATION

PARTS REQUIRED		TOOLS & PPE'S REQUIRED
 <p>RCC351 CATCHCAN</p>	<p>MH9811A PCV HOSE x 1</p> 	<p>* WORK GLOVES * RACHET SET * HOSE CLAMP PLIERS</p>
	<p>MH9811B PCV HOSE x 1</p> 	
	<p>MS4100 PCV HOSE JOINER</p> 	
	<p>MS4091 PCV HOSE CLAMP x 2</p> 	
	<p>MS4094 PCV HOSE CLAMP x 4</p> 	

WORK PROCEDURE

1. Mount the catchcan onto the bracket by sliding the RCC351 nylon bracket onto the catchcan mounting position so it sits behind the factory airbox. Rotate the RCC351 counter clockwise so the ports are facing toward the engine PCV valve and tighten the plastic bracket retaining screw, as per Fig.8 below.
2. Locate the factory PCV valve at the front of the engine, as per Fig. 9. Disconnect the factory PCV hose from the PCV valve but leave it attached to the air intake. Connect the small end of Ryco PCV hose MH9811A to the engine PCV valve outlet using a hose clamp. Route the Ryco PCV hose across the front of the engine, behind the factory air intake system as shown in Fig. 10 and connect to the lower port of the RCC351. Secure with a supplied hose clamp.

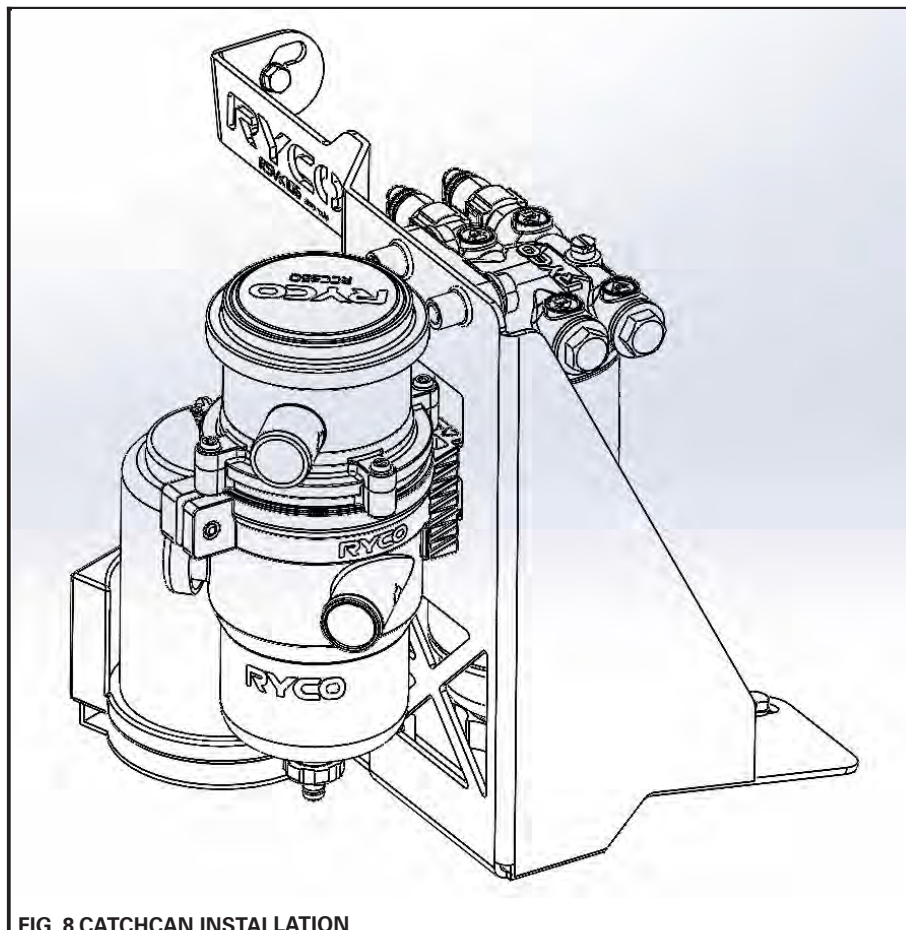

FIG. 8 CATCHCAN INSTALLATION

X106R FUEL WATER SEPARATOR / CATCHCAN FITMENT INSTRUCTIONS

SECTION 3 CATCHCAN INSTALLATION (CONTINUED)

WORK PROCEDURE (CONTINUED)

3. Connect a supplied straight hose joiner to the small diameter end of the Ryco PCV hose MH9811B and secure with a supplied hose clamp. Connect MH9811B to the factory PCV hose via the hose joiner and secure with a supplied hose clamp. Route MH9811B along side MH9811A as per Fig.10 and connect the large diameter end to the upper port of the RCC351 and secure with a supplied hose clamp.
4. Locate the two (2) intercooler mounting brackets as per Fig.10. Secure the two (2) PCV hoses with the supplied cable ties onto the brackets. (Note: Do not tighten the cable ties excessively as the hoses should be allowed to slide)
5. Check both PCV hoses are not jammed or kinked by the surrounding engine parts.

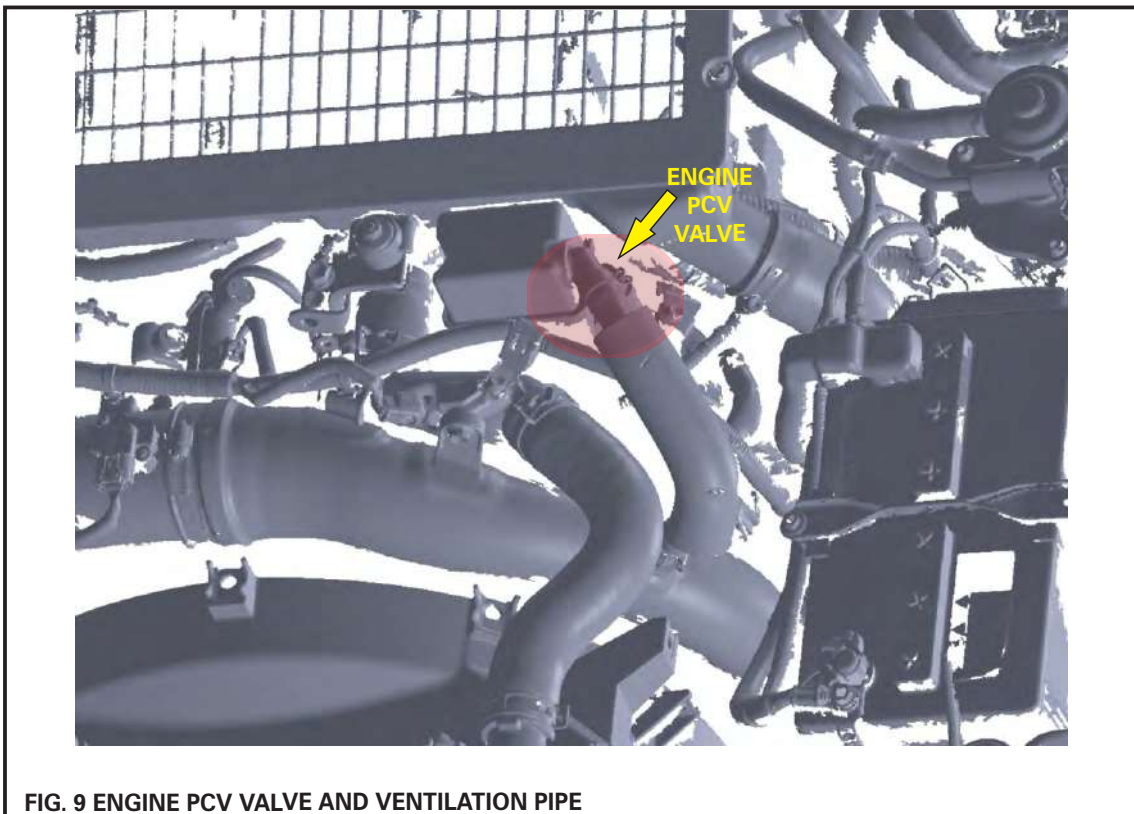
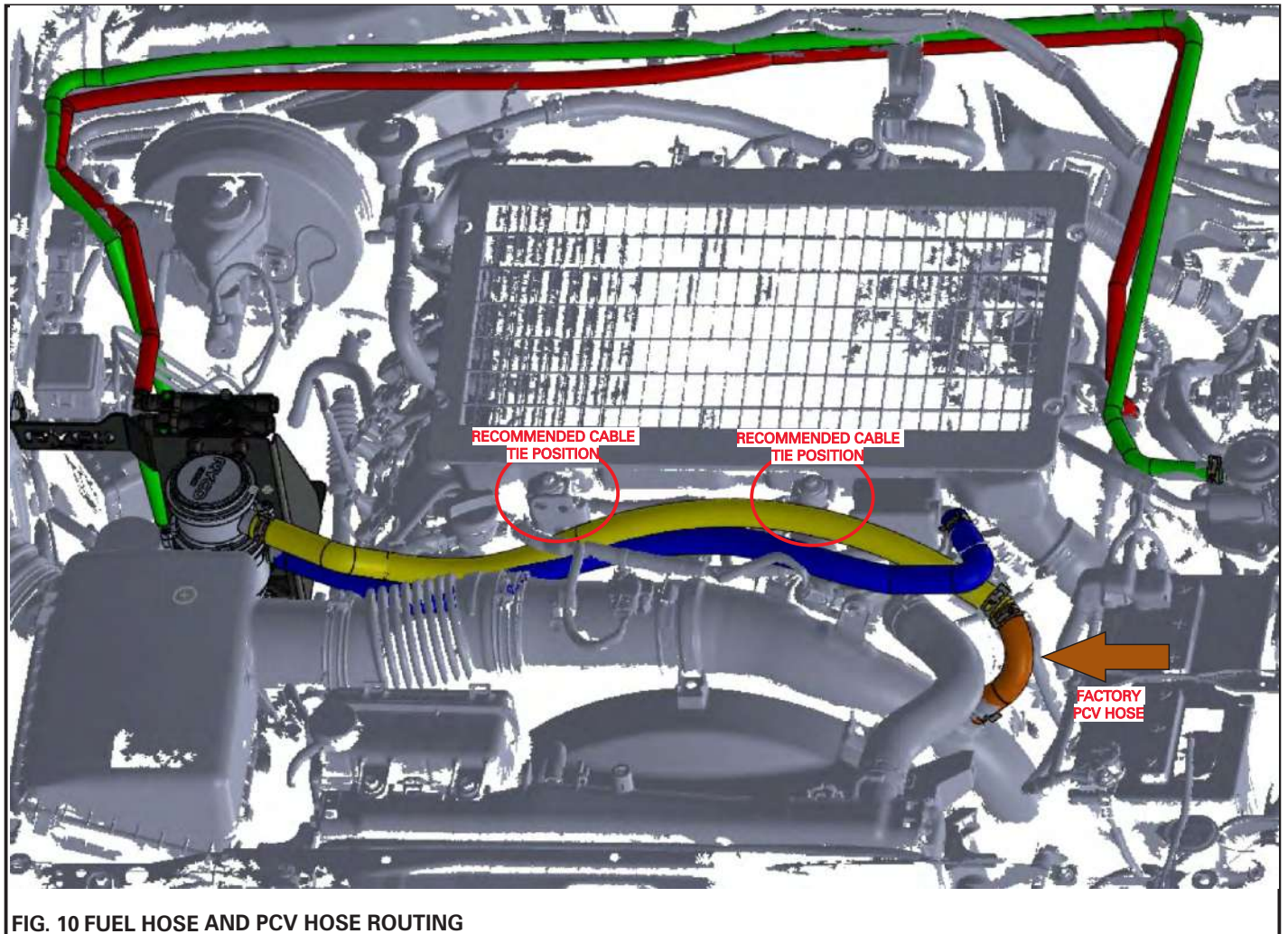

FIG. 9 ENGINE PCV VALVE AND VENTILATION PIPE

DRAIN HOSE INSTALLATION PROCEDURE (OPTIONAL)

1. To install the drain hose, remove the drain plug from the bottom of RCC351, take out the rubber seal from the plug and refit. Insert the drain hose and secure it with the supplied spring clamp. Insert the hose drain tap to the other end and use the zip ties to secure the hose. To drain, pull back the red section until all oil has drained out.
2. If it has been fitted without using the drain hose supplied, simply slide out the unit from its bracket and loosen the drain plug on the unit and let the oil drain onto a pan or bottle.

X106R FUEL WATER SEPARATOR / CATCHCAN FITMENT INSTRUCTIONS



AUSTRALIA
RYCO Group Pty Ltd
29 Taras Avenue, Altona North
Victoria 3025 Australia.
www.rycofilters.com.au

NEW ZEALAND
RYCO Group - A division of GUD (NZ) Holdings Limited
19 Bell Avenue, Otahuhu,
Auckland, 1060 New Zealand.
www.ryco.co.nz

SOCIAL NETWORKS
Facebook: Facebook.com/rycofilters
YouTube: Youtube.com/rycofiltersaus
Twitter: Twitter.com/Ryco_Filters
Instagram: Instagram.com/rycofilters